

4.BLOK II.HVB

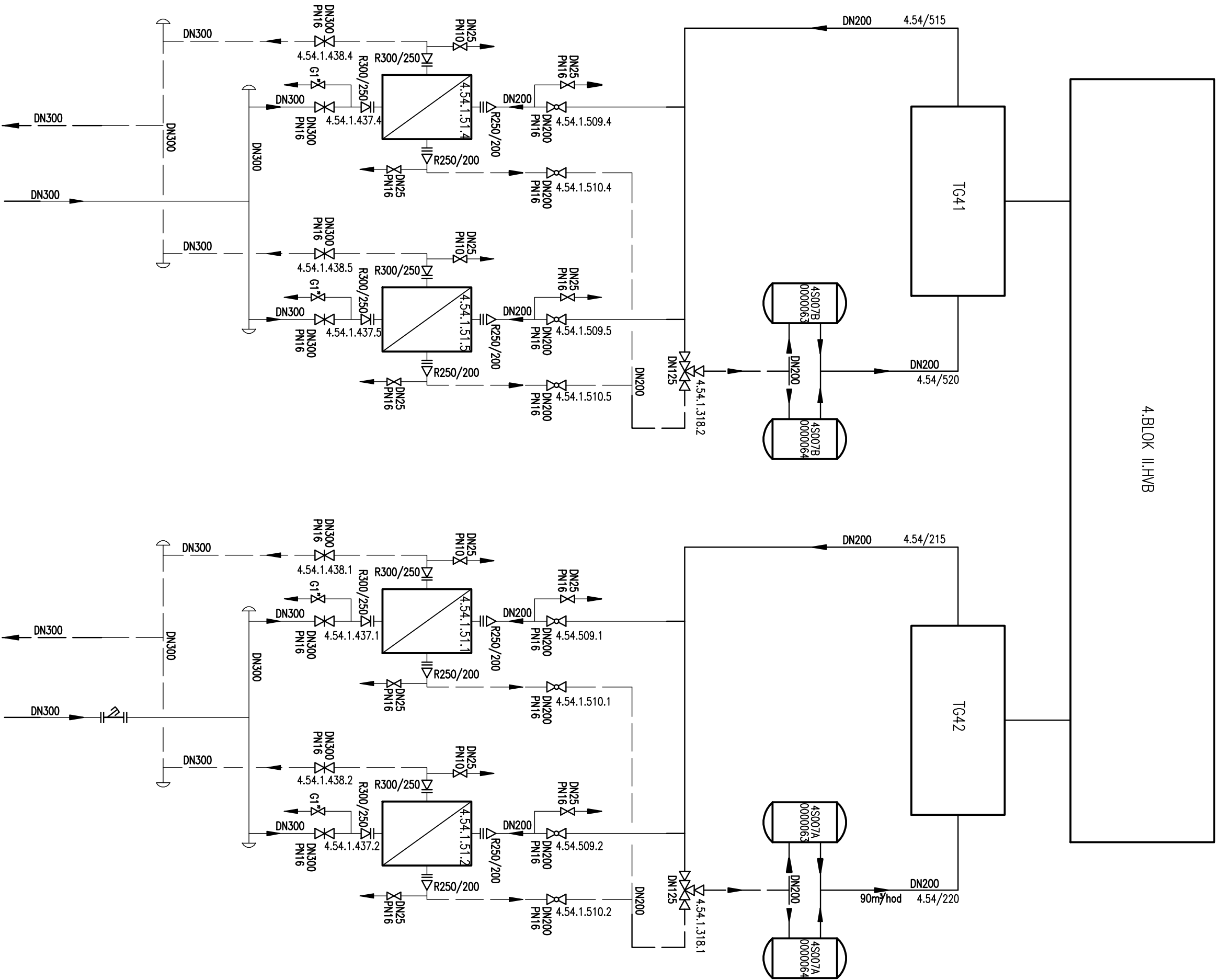

4.BLOK – JEDU

II.HVB – 4.blok – 4x chladič oleje G–MAR 2x100% typ NT250S/367 desek /B–10